

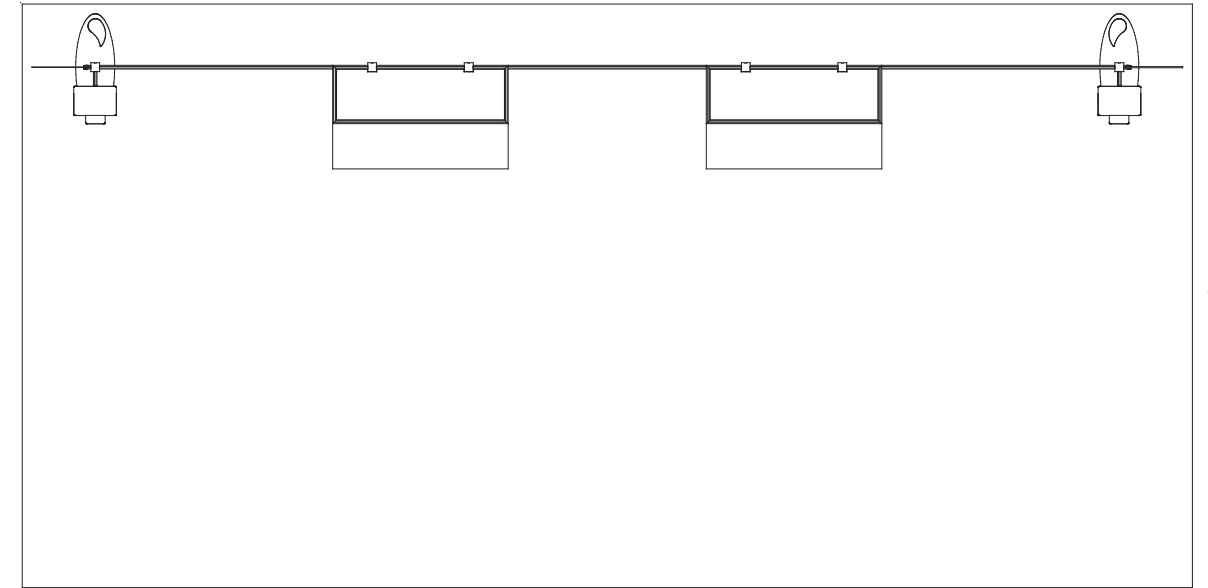

ECO-2108 - 10' x 20' Display

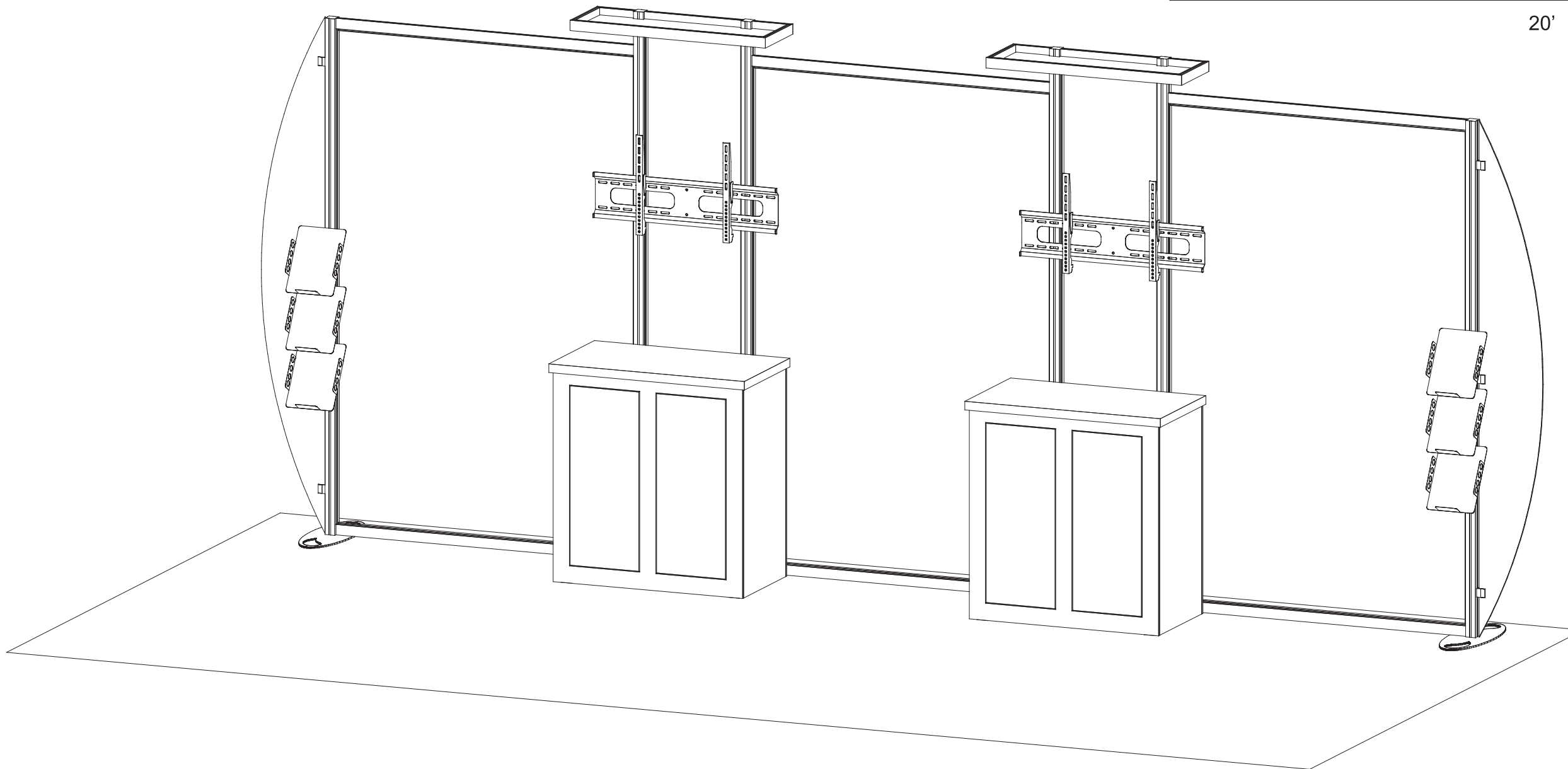

Plan View

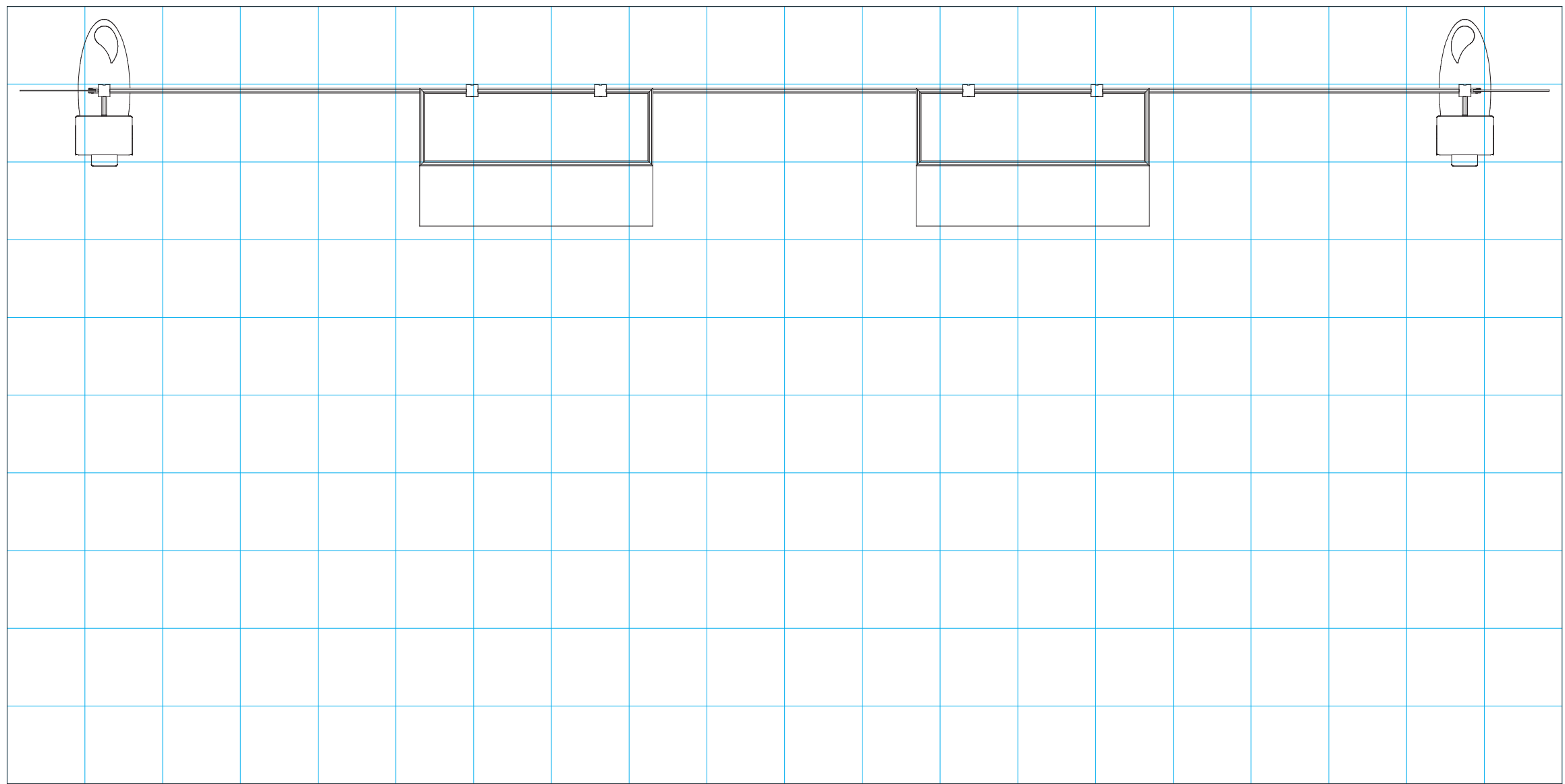



 = 1 sq foot

General Setup Instructions

- Read entire setup instruction manual prior to unpacking parts and pieces.
- The setup instructions are created specifically for this configuration.
- Setup instructions are laid out sequentially in steps, including exploded views with detailed explanation for assembly.

Cleaning & Packing

- For Cleaning Metal, Plex, & Laminate Parts: Use a **MILD NON-ABRASIVE** cleanser and soft cloth/paper towel to clean all surfaces.
- Keep exhibit components away from heat and prolonged sun exposure. **Heat and UV exposure will warp and fade components.**
- Retain all provided Packing Materials. All provided packing materials are for ease of repacking & component protection.

Disassembly

- For loss prevention, tighten all set screws and locks during disassembly.

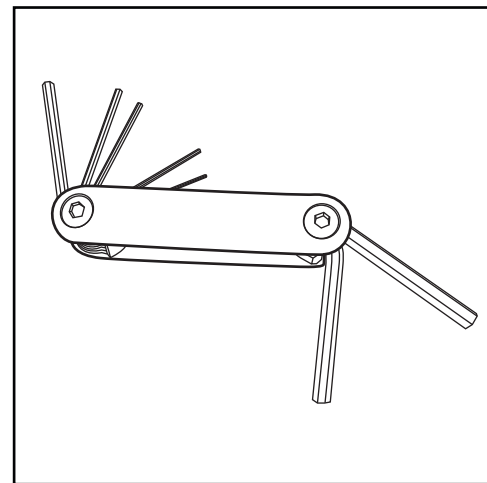

Hex Tool - Essential for Assembly

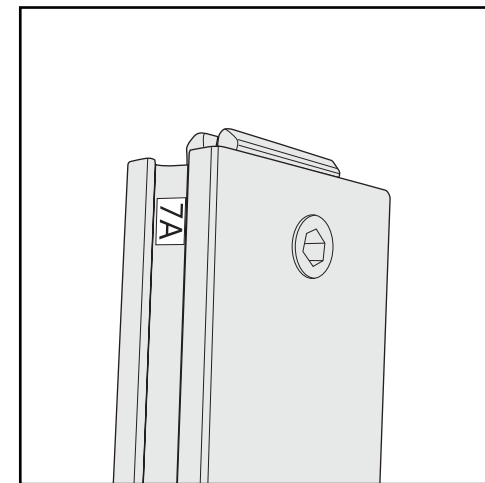

Part Identification - Numbering

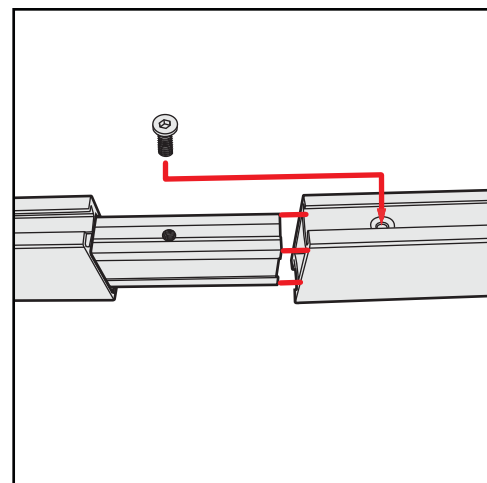

Spline Connection

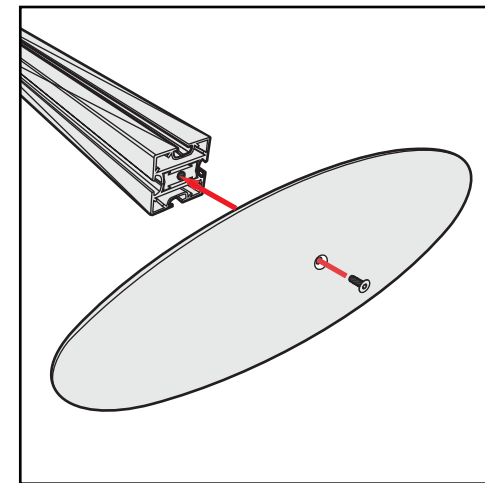

Base Plate & Extrusion Connection

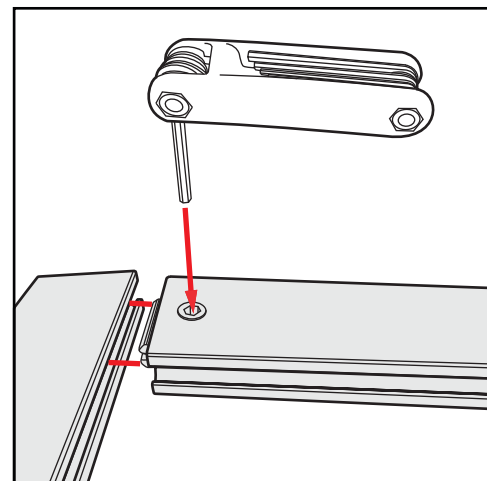

Extrusion & Lock Connection

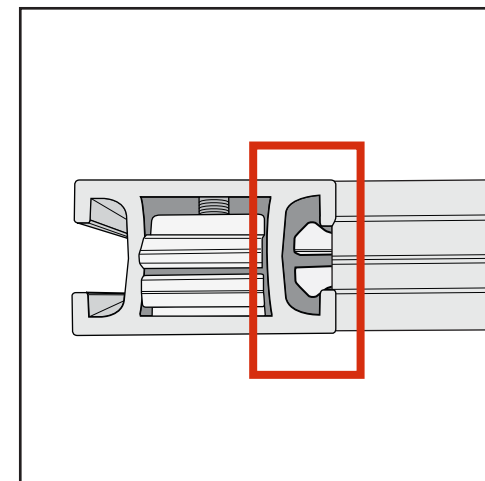

Engaged Lock



WARNING



DO NOT USE POWER TOOLS



LADDERS OR LIFTS
MAY BE REQUIRED



ALL CONNECTIONS MUST
BE TIGHTLY SECURED

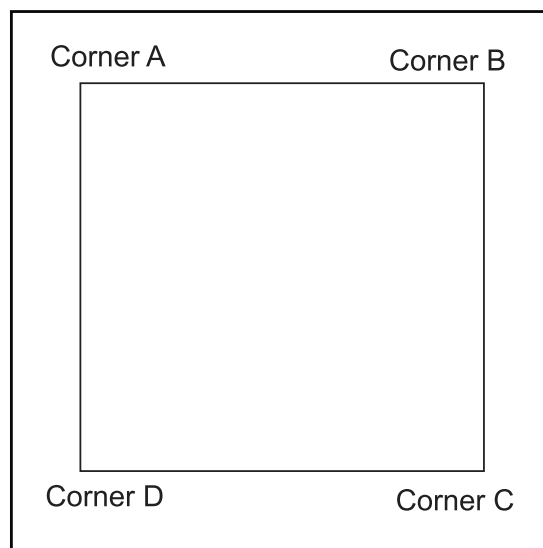

It is important to first insert graphic into each alternate corner then to the sides of the frame. If this is not done, graphic will not fit into the frame correctly.

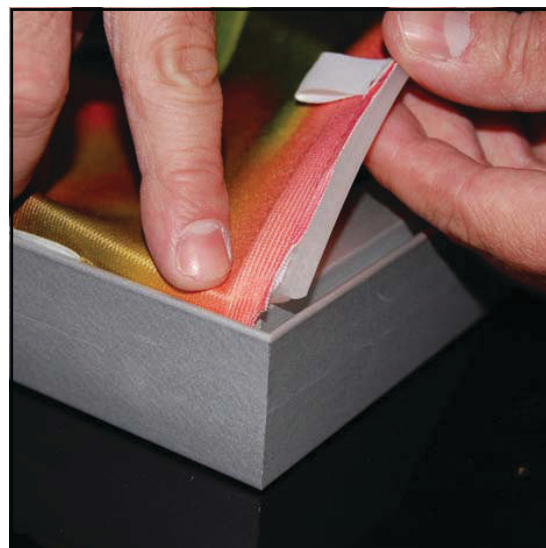

Step 1
Insert corner A. Turn edge of graphic so silicon welt is perpendicular to face of graphic. Insert narrow side of welt with fabric to outside into the channel. Repeat for other side of this corner.



Step 2
Repeat Step 1 for opposite corner C, then insert corner B, followed by corner D, to complete the installation of the corners.

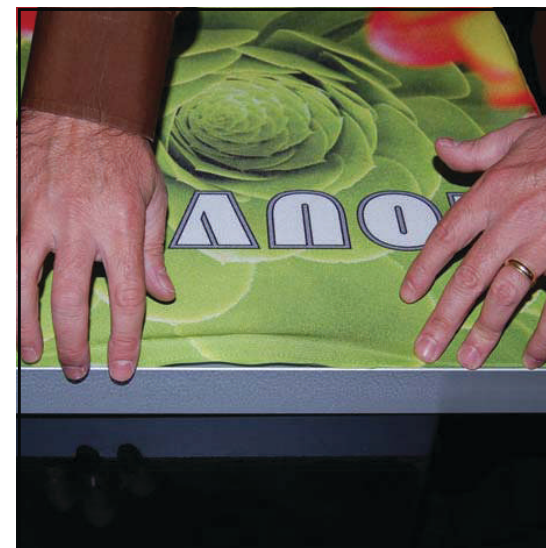

Step 3
Once all corners are inserted, press one silicon edge into channel from corners and work toward the center. Make sure welt is fully inserted into channel. Continue until all sides are done. Smooth out edges of graphic.

Graphic Removal

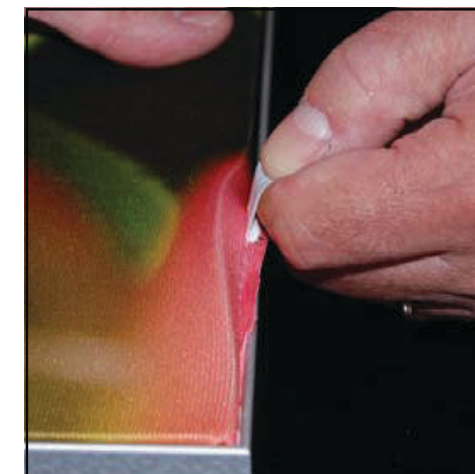

To remove the graphic from the frame, locate the fabric pull tab. Gently pull up on the tab to remove the fabric.

Crate Packing

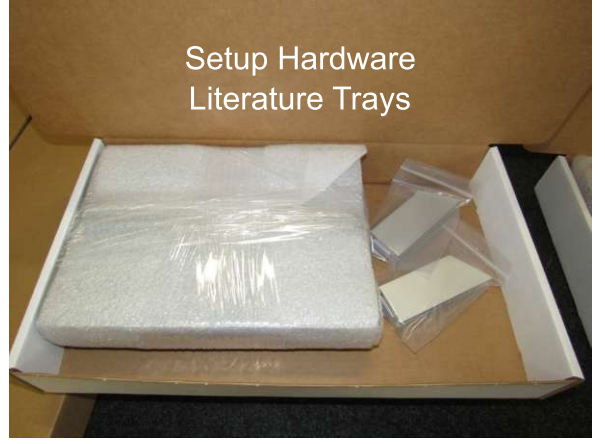
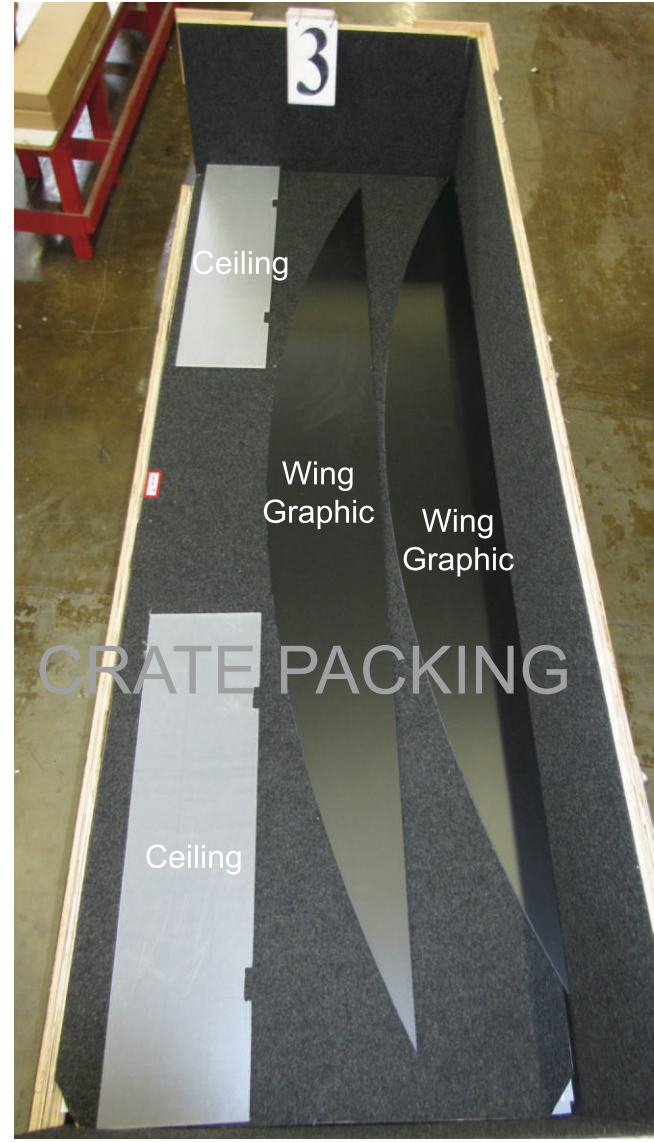
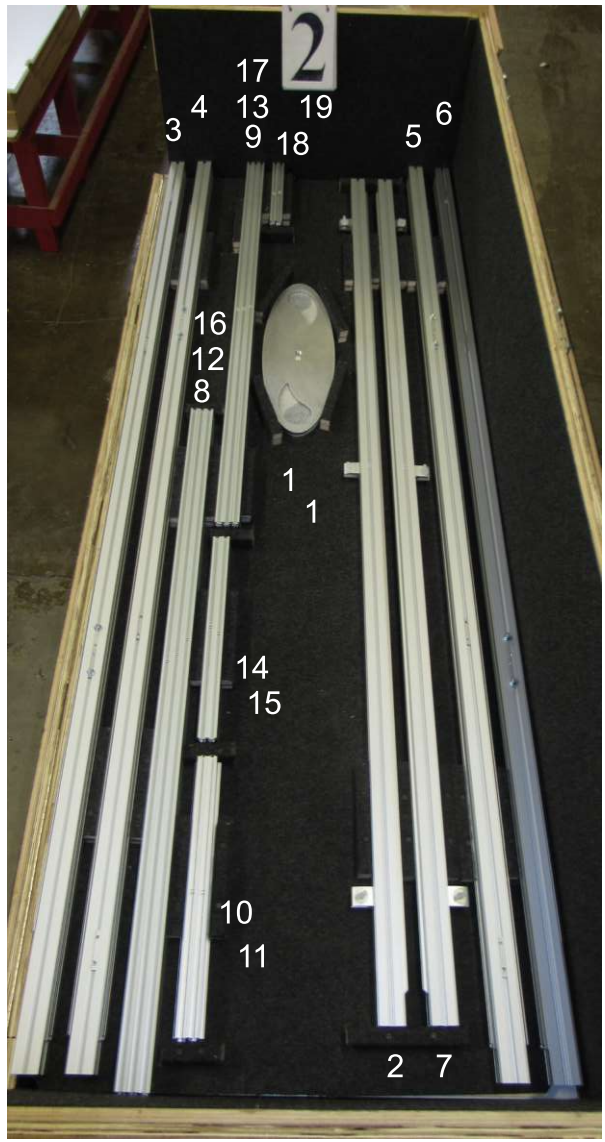

Backwall Assembly

Item	Qty.	Description
1	2	Base Plate
2	1	90"h S44 Vertical Extrusion w/ TSP3
3	1	96"h S44 Vertical Extrusion w/ TSP3
4	1	96"h S44 Vertical Extrusion w/ TSP3
5	1	96"h S44 Vertical Extrusion w/ TSP3
6	1	96"h S44 Vertical Extrusion w/ TSP3
7	1	90"h S44 Vertical Extrusion w/ TSP3
8	1	55"w Z45 Horizontal Extrusion w/ TSP3
9	1	55"w Z45 Horizontal Extrusion w/ TSP3
10	1	18"w Z45 Horizontal Extrusion w/ TSP3
11	1	18"w Z46 Horizontal Extrusion w/ TSP3
12	1	55"w Z45 Horizontal Extrusion w/ TSP3
13	1	55"w Z45 Horizontal Extrusion w/ TSP3
14	1	18"w Z45 Horizontal Extrusion w/ TSP3
15	1	18"w Z46 Horizontal Extrusion w/ TSP3
16	1	55"w Z45 Horizontal Extrusion w/ TSP3
17	1	55"w Z45 Horizontal Extrusion w/ TSP3

Steps:

- 1) Connect Base Plates [1] to bottom of verticals [2,7], using bolts.
- 2) Assemble horizontals [8,9], [10,11], [12,13], [14,15], [16,17] between verticals [2,3,4,5,6,7] as shown.

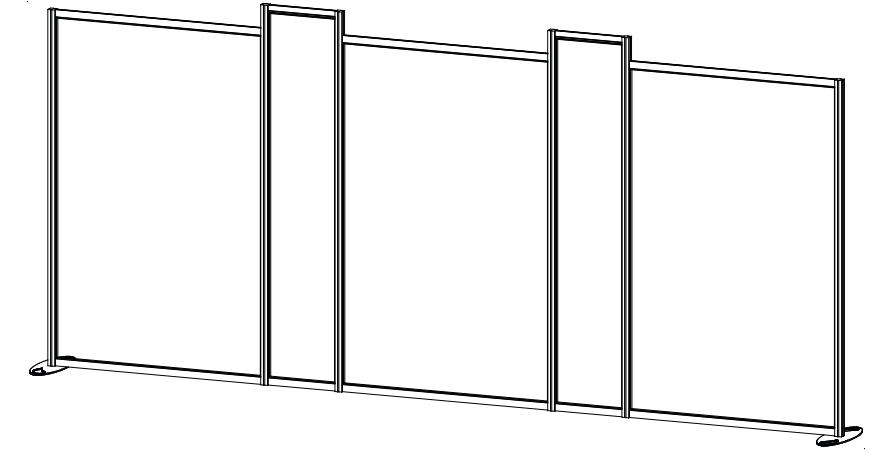

When assembled

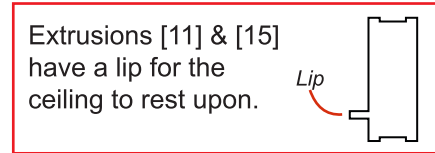

Assemble frame flat on ground.

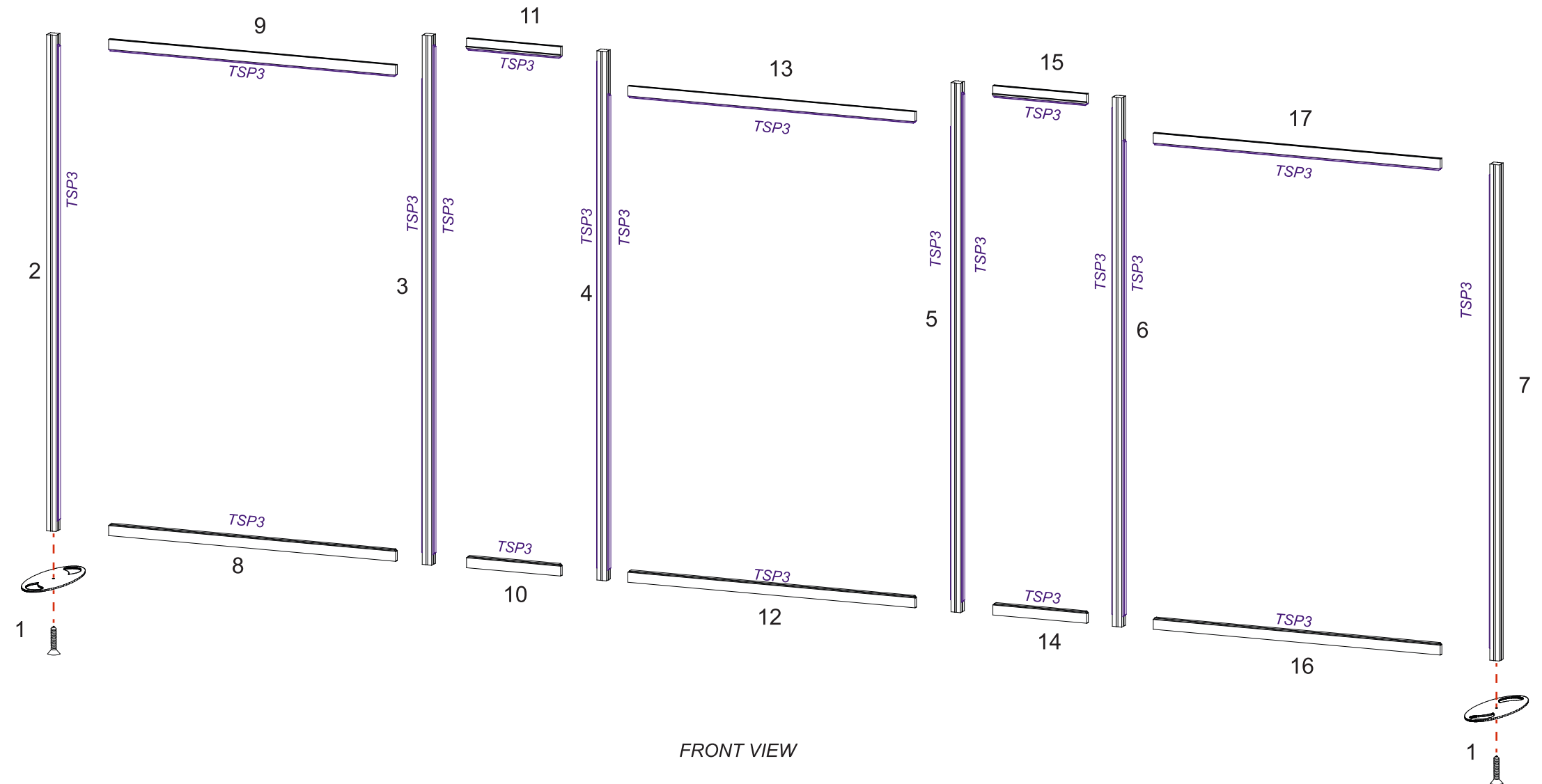
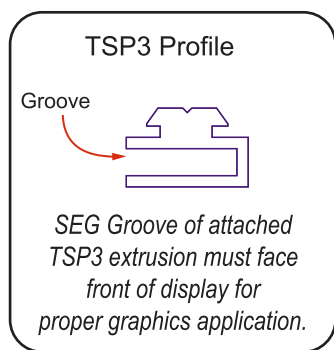

SEG Graphic Installation

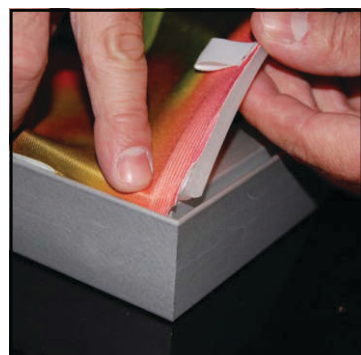
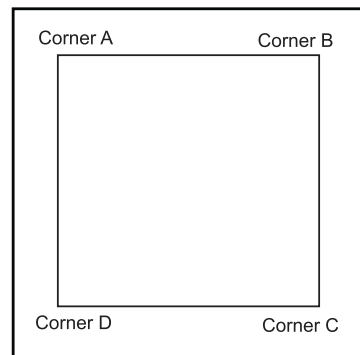

It is important to first insert graphic into each alternate corner, then to the sides of the frame. If this is not done, graphic will not fit into the frame correctly.

Step 1
Insert corner A. Turn edge of graphic so silicon welt is perpendicular to face of graphic. Insert narrow side of welt with fabric to outside into the channel. Repeat for other side of this corner.

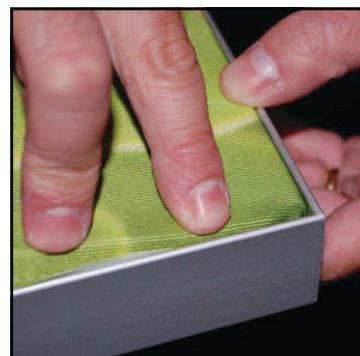

Step 2
Repeat Step 1 for opposite corner C, then insert corner B, followed by corner D, to complete the installation of the corners.

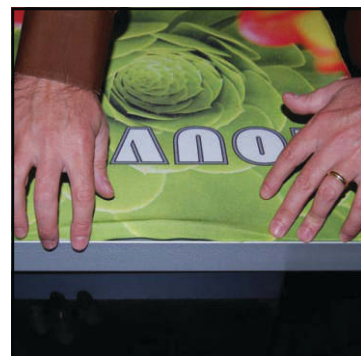

Step 3
Once all corners are inserted, press one silicon edge into channel from corners and work toward the center. Make sure welt is fully inserted into channel. Continue until all sides are done. Smooth out edges of graphic.

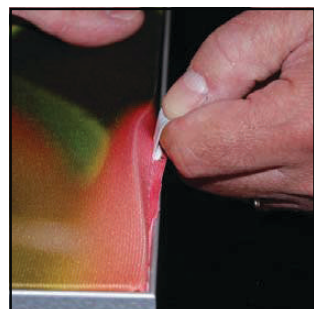

Graphic Removal
To remove the graphic from the frame, locate the fabric pull tab. Gently pull up on the tab to remove the fabric.

Steps:
1) Apply SEG graphics to TSP3 extrusions on backwall.

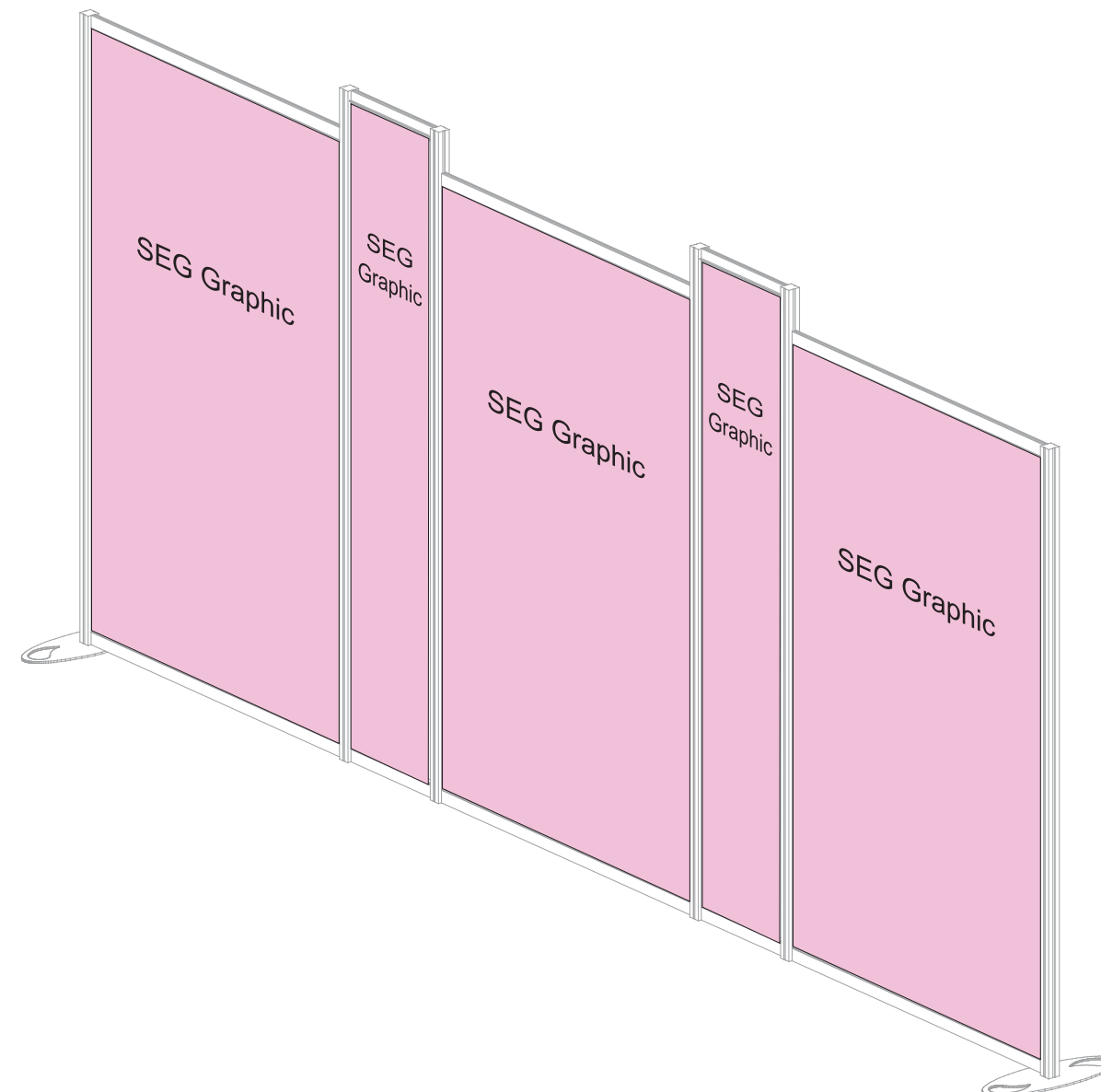

Backwall Attachments

Item	Qty.	Description
1	2	7.189"w Z46 Horizontal Extrusion
2	2	12"w Z46 Horizontal Extrusion
3	2	36"w Z46 Horizontal Extrusion
4	2	12"w Z46 Horizontal Extrusion
5	2	7.189"w Z46 Horizontal Extrusion
--	2	Eco Glass Ceiling Panel

Steps:

- 1) Assemble extrusions [1,2,3,4,5] together using corner connectors. Repeat step for other ceiling assembly.
- 2) Attach assemblies [1/2/3/4/5] to backwall verticals [3,4] & [5,6] as shown.
- 3) Place Ceiling Panels onto assemblies [1/2/3/4/5].

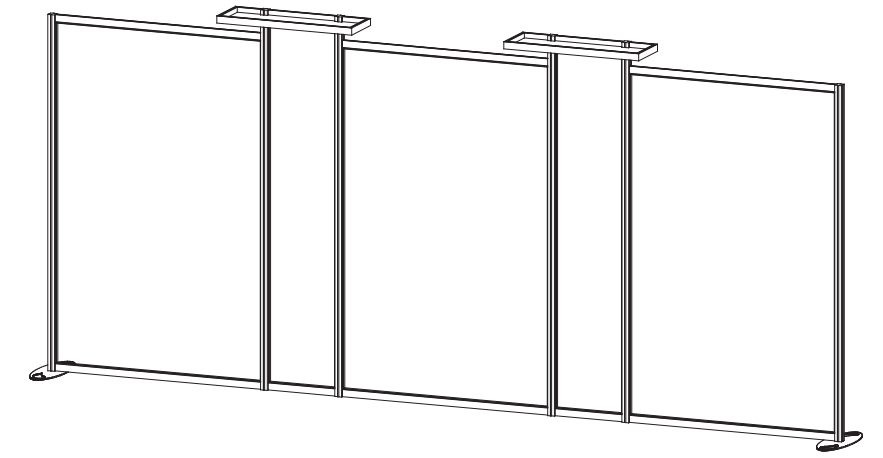

When assembled

Z46 Extrusions have a lip for the ceiling to rest upon.

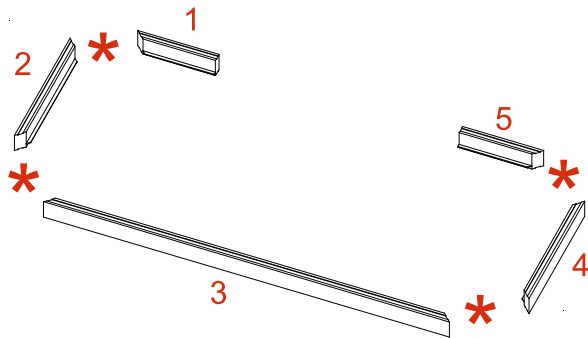

Qty. 2

*** Z46 Corner Connection**

Insert corner connector into extrusion & secure set screw.
Slide adjacent extrusion over connector, secure set screw.

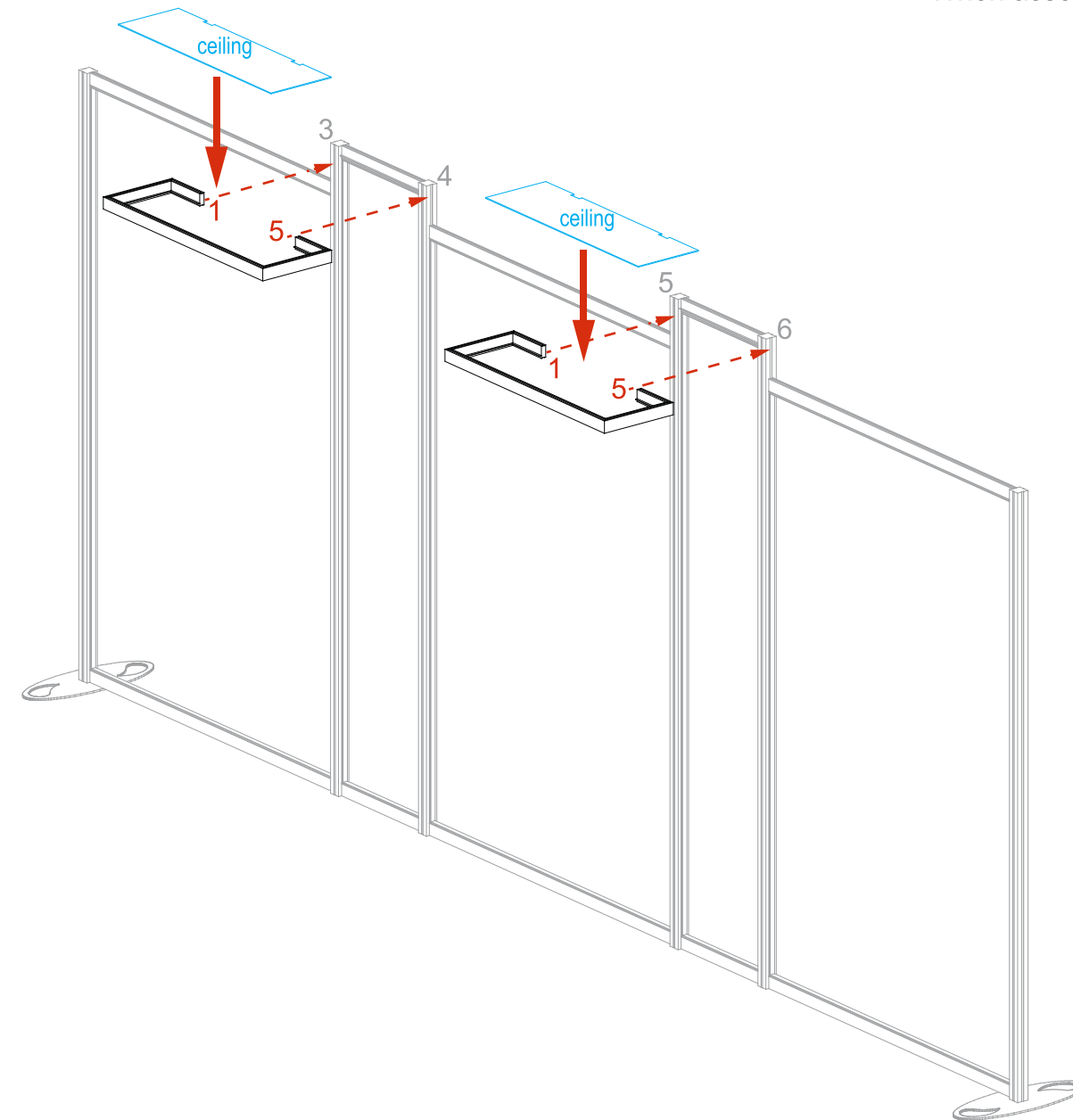
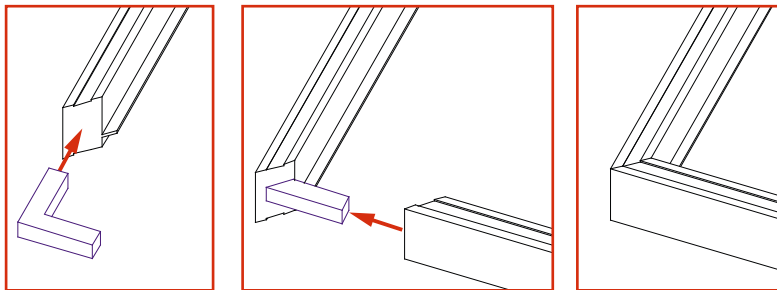

Backwall Attachments (cont'd)

Steps:

- 1) Attach Wings to sides of backwall assembly. See [Wing Attachment](#) detail.
- 2) Connect Literature Trays to verticals [2,7]. See [Literature Tray Attachment](#) detail.
- 3) Install Monitor Mounts to verticals [3,4] & [5,6]. See [Monitor Mount Attachment](#) detail.
- 4) Attach Cabinets to verticals [3,4] & [5,6]. See [Cabinet Attachment](#) detail.

*** Wing Attachment**

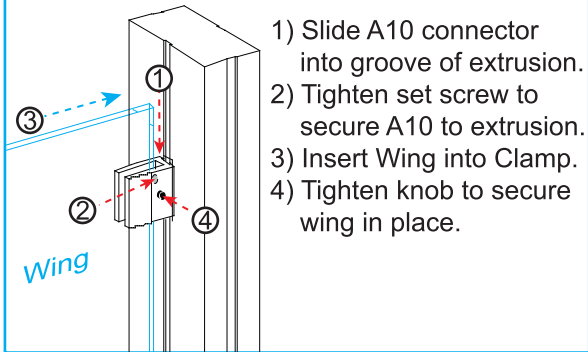

*** Literature Tray Attachment**

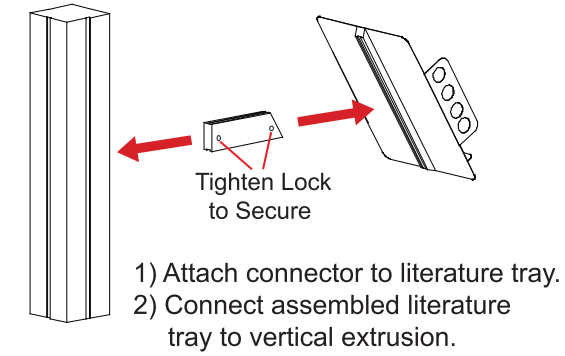

*** Monitor Mount Attachment**

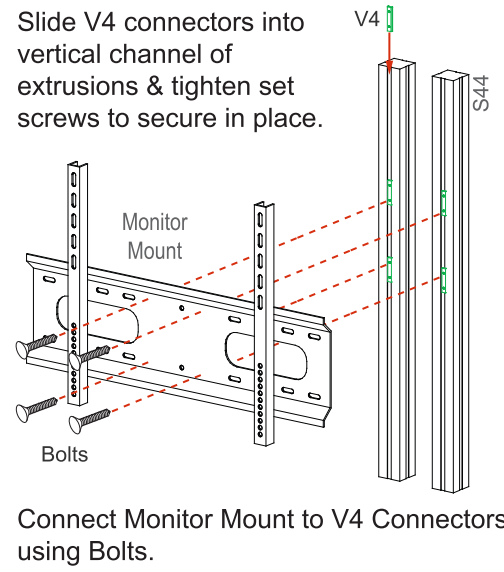

*** Cabinet Attachment**

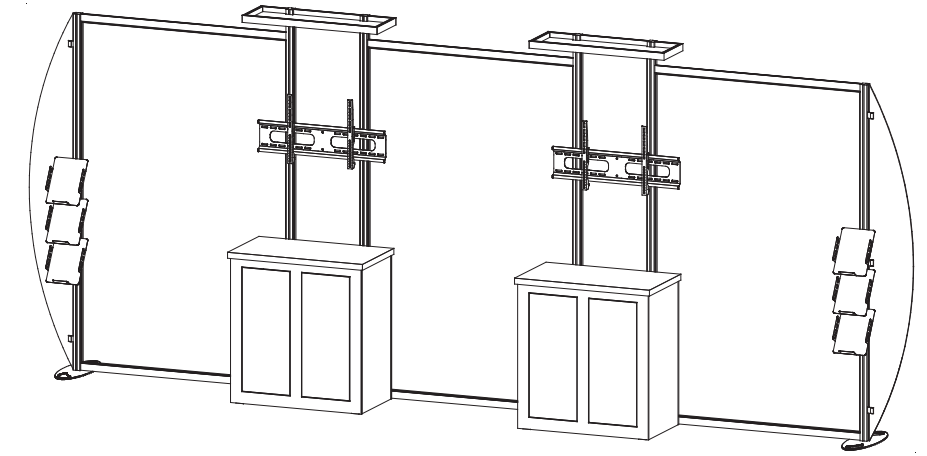
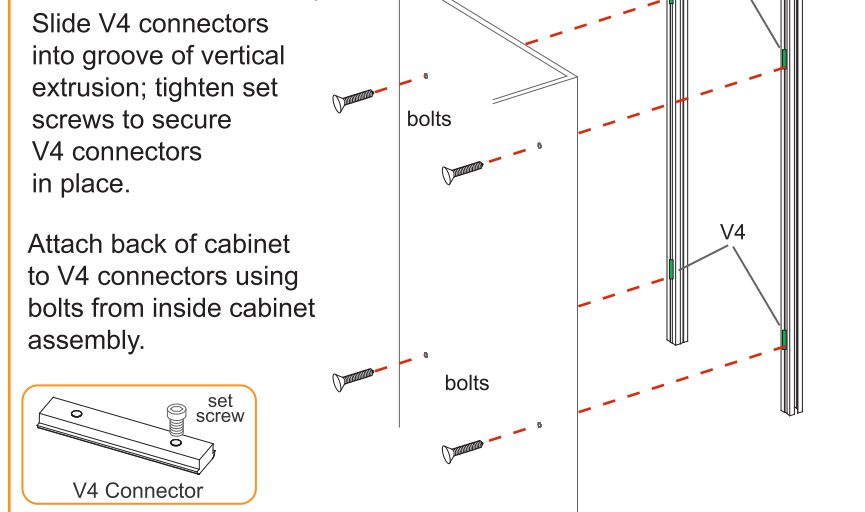

Completed Assembly

